

PowerTech™

6090AFM85 Diesel Engine

Marine Generator Drive Engine Specifications

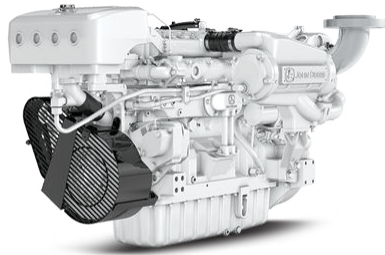

6090AFM85 shown

Dimensions

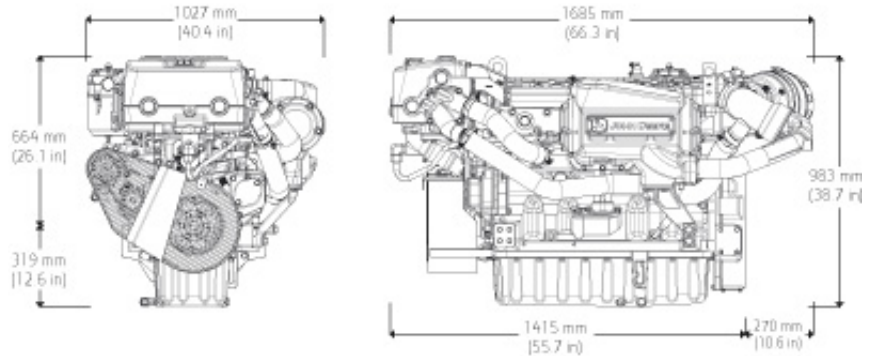

Dimensions shown in mm (in) may vary according to options selected. Contact your distributor for more information.

Emissions

EPA Commercial Marine Tier 3
IMO MARPOL Annex VI Compliant

General Data (Based on Standard Option Configuration)

Model	6090AFM85	Length maximum - mm (in)	1685 (66.3)
Number of cylinders	6	Length to rear face of flywheel housing - mm (in)	1415 (55.7)
Displacement - L (cu in)	9.0 (549)	Flywheel housing SAE	2
Bore and Stroke-- mm (in)	118 x 136 (4.65 x 5.35)	Height - mm (in)	983 (38.7)
Engine Type	In-line, 4-cycle	Height, crankshaft centerline to top - mm (in)	664 (26.1)
Aspiration	Turbocharged and air-to-coolant aftercooled	Height, crankshaft centerline to bottom - mm (in)	319 (12.6)
		Weight, dry - kg (lb)	1055 (2326)

Classification Societies

ABS,BV,CCS,DNV-GL,LR

* SOLAS and other accessories available. Contact your distributor for details.

Features and Benefits

Optional Low RPM Operation

- A lower speed option provides the user the ability to start the engine without going to the gen-set rated speed and allows the user to clutch in an accessory that may be driven by the engine.

4-Valve Cylinder Head

- Excellent airflow through 4-valve cylinder head delivers greater low-speed torque and better transient response time.

High-pressure Common-rail (HPCR)

- The HPCR fuel system provides variable common-rail pressure, multiple injections, and controls fuel injection timing and provides precise control for the start, duration, and end of injection.

Water-cooled Exhaust Manifold

- Integrated components eliminate external hoses and fittings that can leak or break. Wet exhaust manifold creates a cooler and quieter environment for passengers and crew.

Replaceable Cylinder Liners

- Replaceable wet-type cylinder liners are precision-machined and hardened for long life. Allows engine to be rebuilt to original specifications.

Electronic Engine Control Unit (ECU)

- Advanced fault code diagnostics and customizable engine protections ensure reliability and uptime. Provides highly customizable features and trim to integrate your vessel.

Keel-cooled or Heat Exchanger

- Closed cooling system in keel-cooled engine option eliminates the need for a sea strainer, seawater pump, or anodes. Heat exchanger option offers a lighter, more compact, and simpler engine installation.

Multiple Service Options

- Either-side oil fill/dipstick combinations and remote oil and fuel filter options are available for easier service access.

Performance Curves

50Hz (1500 rpm)

60Hz (1800 rpm)

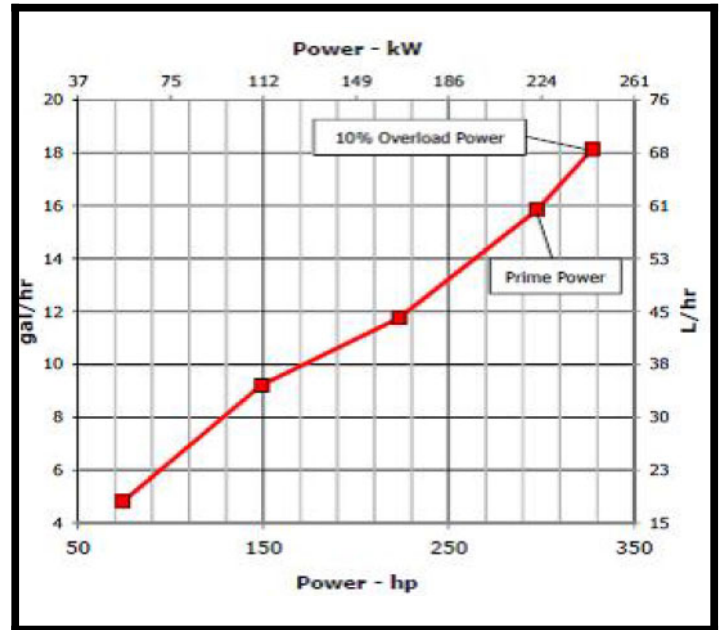
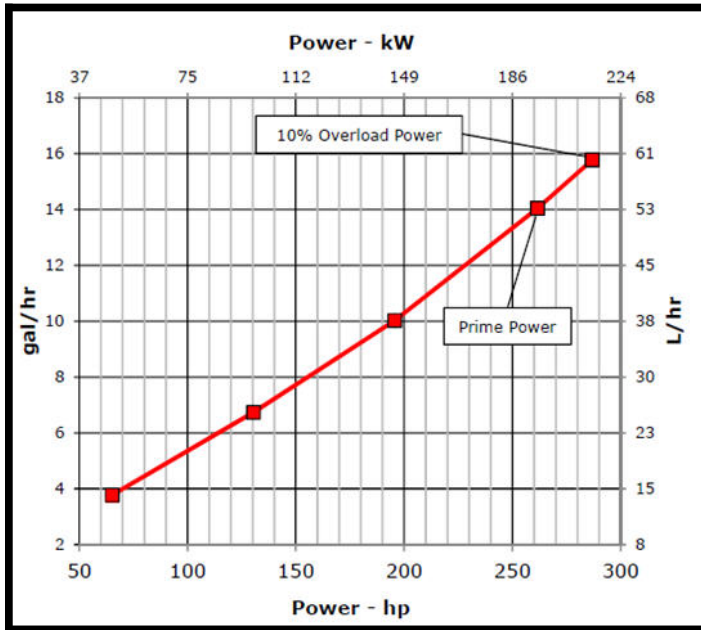

Performance data points shown at 25%, 50%, 75%, 100%(prime), and 110%(overload) power.

Calculated Generator-Set Rating

Rated speed Hz (rpm)	Generator efficiency %	Engine power		Power factor	Calculated generator set rating	
		Prime*			Prime*	
		kW	hp		kWe	kVA
50 (1500)	88-92	195	262	0.8	171-179	214-224
60 (1800)	88-92	222	298	0.8	195-204	244-255

* Prime power is the normal power an engine is capable of delivering with a variable load for an unlimited number of hours per year. This rating conforms to ISO 3046 and SAE J1995. This rating incorporates a 10 percent overload capability, and conforms to ISO 8528 prime power.

See your John Deere Power Systems engine distributor or marine dealer for more detailed performance information.