

# T4.270

## SPECIFICATIONS

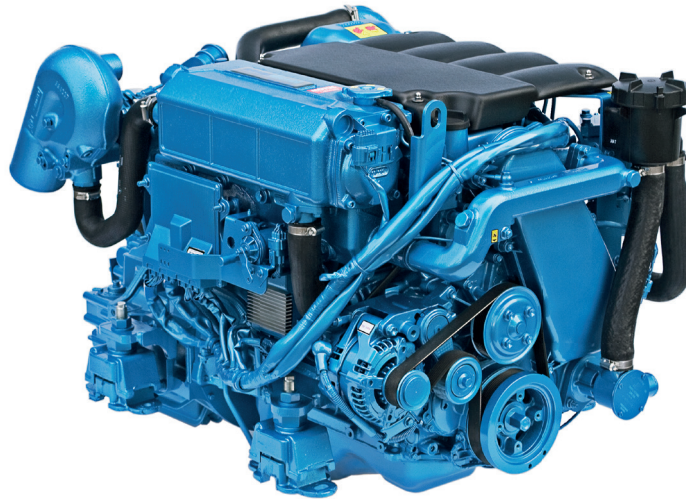

Power at crankshaft	194.9 kW [265 hp]	Engine base	Toyota
Displacement	2.982 l [182 in <sup>3</sup> ]	Fuel system	Direct injection High pressure Common Rail Electronically controlled
Configuration	4 cylinders in line	Air intake	Turbocharged with intercooler
Operation type	4 strokes Diesel	Cooling	Closed cooling with heat exchanger
Bore & Stroke	96 x 103 mm [3.78 x 4.06 in]	Max mounting angle	7° Front down 7° Front up
Compression ratio	15 : 1	Alternator	12 Volt 130 Amp
Rated speed	3600 rpm	Rating	M6
Idling speed	730 rpm	Emission compliance	IMO Annex VI Compliant RCD 2013/53/EU EPA marine Tier 3 BSO2
Peak torque	660 Nm	Dry weight with TTM50A	393 kg [866 lbs]
Peak torque speed	2000 rpm		

# T4.270

194.9 kW [265 hp] at 3600 rpm

## TECHNICAL DESCRIPTION

### ENGINE BLOCK

- 4 cylinders in line
- 4 valves per cylinder
- Dual overhead camshaft (DOHC)
- Watercooled exhaust manifold
- Internal balancers

### FUEL SYSTEM

- Common Rail injection system
- Fuel filter with hand primer
- Integrated fuel cooler

### LUBRICATION SYSTEM

- Replacable full-flow oil filter
- Oil dipstick
- Transmission oil cooler

### COOLING SYSTEM

- Closed cooling with heat exchanger
- Gear driven self-priming raw water pump
- Coolant circulating pump
- Water cooled exhaust elbow

### ELECTRICAL SYSTEM & INSTRUMENTATION

- 12 V / 100 A alternator
- 12 V Electrical system
- Complete instrumentation including key switch and alarms
- Extension cable harness with plug-in connection

### AIR INTAKE

- Dry turbocharger
- Intercooler

### OTHER FEATURES

- Flexible engine mountings

### OPTIONAL EQUIPMENTS & ACCESSORIES

- Complete marine propulsion systems
- Marine transmission adaptation kits
- Throttle and shift controls
- Additional instrumentation, Flying bridge extension harness
- Water boiler systems
- Complete fuel systems
- Complete exhaust systems
- Trolling valve

### RATINGS

- Up to 500 annual operating hours
- Load factor up to 35%
- Full power for no more than 30 minutes out of each 8 hours of operation. The remaining time must be at, or below cruising speed

### TRANSMISSIONS

#### SHAFT LINE

- TTM40A
- TTM50A
- ZF63A

#### STERN DRIVE

- Bravo X One
- Bravo X Three
- Bravo X Two
- Contact your local Nanni dealer for more details and availability for transmission model and type.

## PERFORMANCE CURVES

### POWER AT CRANKSHAFT

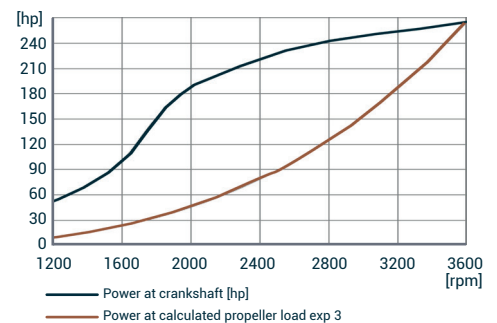

### TORQUE AT CRANKSHAFT

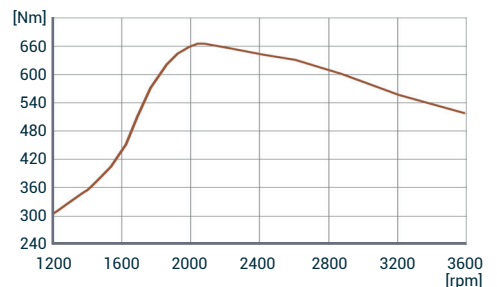

### FUEL CONSUMPTION

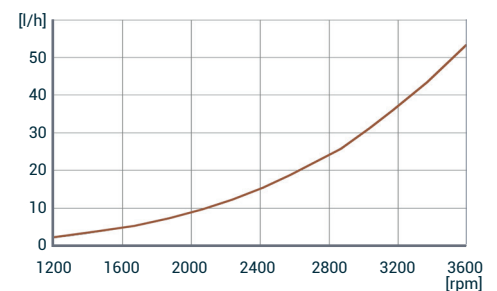

## DIMENSIONS WITH TTM50A

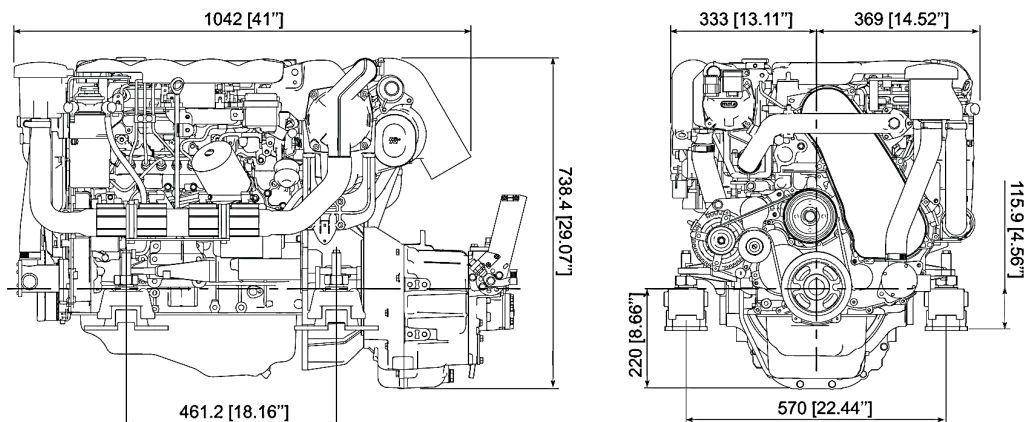

## NANNI INDUSTRIES S.A.S.

11, Avenue Mariotte - Zone Industrielle  
33260 La Teste - France  
Tel: +33 (0)5 56 22 30 60  
Fax: +33 (0)5 56 22 30 79

Technical data according to ISO 8665. This document is not contractual. Nanni reserves the right to modify any of the characteristics stated in this document without notice, in a constant effort to improve the quality of its products. Images and illustrations may show non standard equipments. All combination of equipment & accessory are not available.

DGBXXC01014A