

N5.160 CR2

SPECIFICATIONS

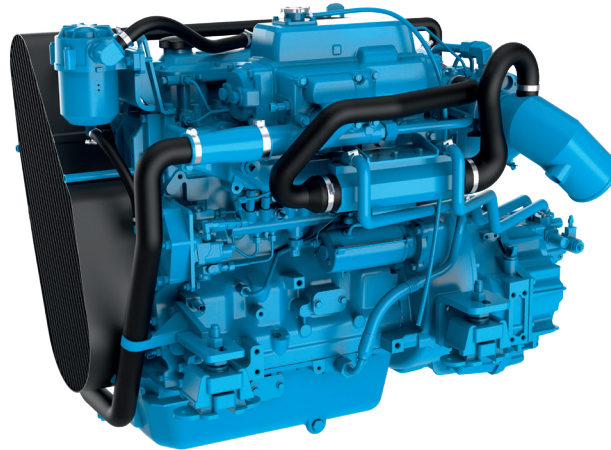

Power at crankshaft	119 kW [162 hp]	Engine base	John Deere
Displacement	4.5 l [275 in ³]	Fuel system	Direct injection Mechanical governor electronically controlled
Configuration	4 cylinders in line	Air intake	Turbocharged Air-to-seawater aftercooler
Operation type	4 strokes Diesel	Cooling	Closed cooling with heat exchanger
Bore & Stroke	106.4 x 127 mm [4.19 x 5 in]	Max mounting angle	0° Front down 12° Front up
Compression ratio	16.7 : 1	Alternator	24 Volt 50 Amp
Rated speed	2300 rpm	Rating	M1
Idling speed	600 rpm	Emission compliance	IMO Annex VI compliant EPA marine Tier 3 NRMM 97/68/EC RCD 2013/53/EU
Peak torque	604 Nm	Dry weight	578 kg [1274 lbs]
Peak torque speed	1800 rpm		

N5.160 CR2

119 kW [162 hp] at 2300 rpm

TECHNICAL DESCRIPTION

ENGINE BLOCK

- Replaceable wet-type cylinder liners
- 4 valves per cylinder
- Watercooled exhaust manifold

FUEL SYSTEM

- Common Rail fuel injection system
- Fuel heater
- Primary & secondary fuel filter

LUBRICATION SYSTEM

- Replaceable full-flow oil filter
- Oil dipstick
- Oil cooler

COOLING SYSTEM

- Closed cooling with heat exchanger
- Gear driven self-priming raw water pump
- Coolant circulating pump
- Water cooled exhaust elbow

ELECTRICAL SYSTEM & INSTRUMENTATION

- 24V / 50A alternator
- 24V starter motor
- Complete instrumentation including key switch and alarms
- Extension cable harness with plug-and-play

AIR INTAKE

- Turbocharged
- Air-to-seawater aftercooler

OTHER FEATURES

- Flywheel SAE 3
- Flexible engine mounting
- Internal balancers

OPTIONAL SYSTEMS & ACCESSORIES

- Keel cooling adaptation
- Dry exhaust elbow
- Complete marine propulsion systems
- Marine transmission adaptation kits
- Throttle and shift controls
- Additional instrumentation, Flying bridge extension harness
- Rigid engine mounting
- Power take off

RATINGS

- 24 daily operating hours
- Load factor up to 65%
- Uninterrupted full power

TRANSMISSIONS

- Contact your Nanni representative for more details and availability about transmissions types and models range

PERFORMANCE CURVES

POWER AT CRANKSHAFT

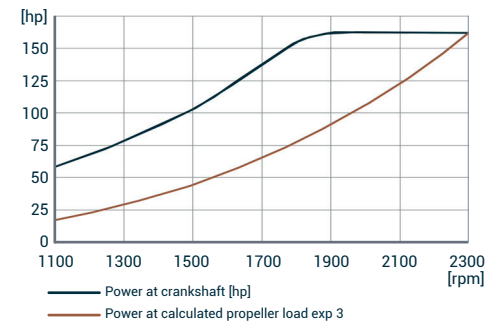

TORQUE AT CRANKSHAFT

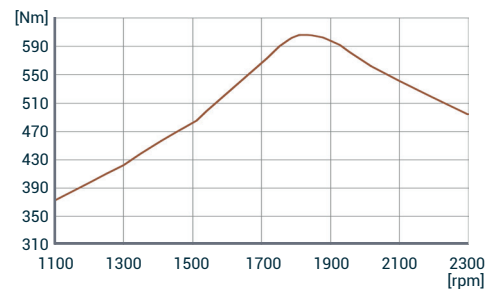

FUEL CONSUMPTION

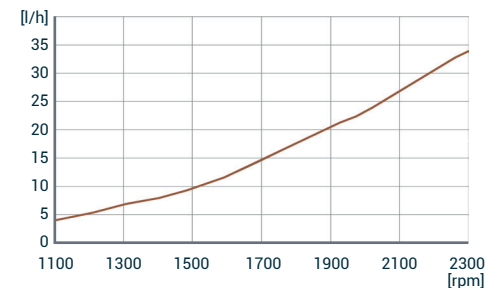

DIMENSIONS BOBTAIL

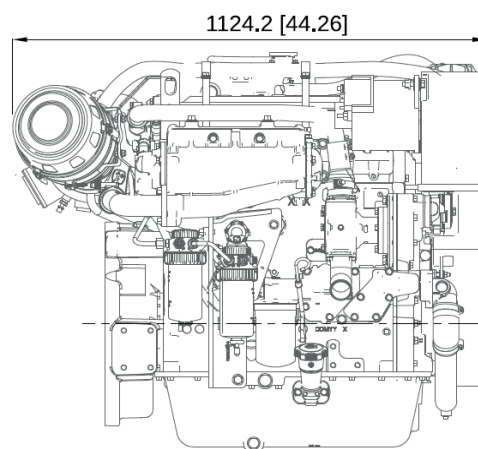
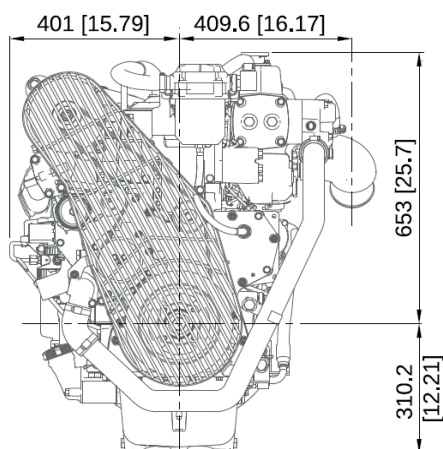

NANNI INDUSTRIES S.A.S.

11, Avenue Abbé Mariotte
33260 La Teste - France
Tel +33 (0)5 56 22 30 60
www.nannienergy.com

NANNI SRL

Via degli Olmetti, 44/A
00060 Formello - Roma - Italia
Tel +39 06 30 88 42 51
www.nannienergy.com

Technical data according to ISO 8665. This document is not contractual. Nanni reserves the right to modify any of the characteristics stated in this document without notice, in a constant effort to improve the quality of its products. Images and illustrations may show non standard equipments. All combination of equipment & accessory are not available.

DGBXXC01026B