

# N6.405 CR2

## SPECIFICATIONS

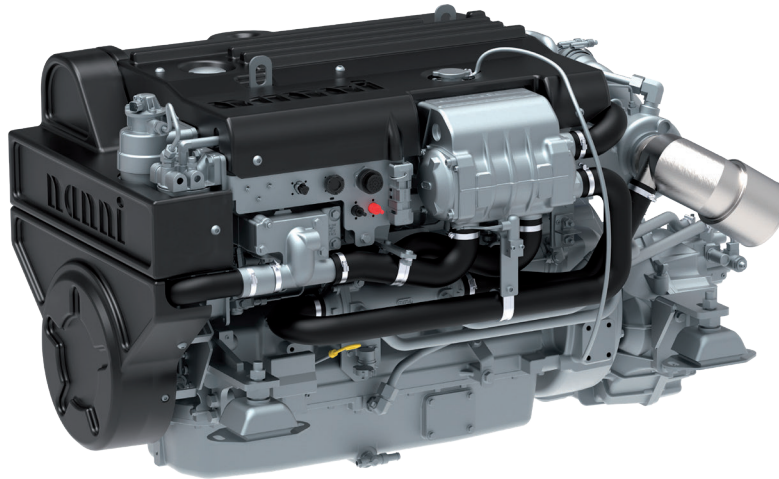

Power at crankshaft	298 kW [405 hp]	Engine base	John Deere
Displacement	6.8 l [415 in <sup>3</sup> ]	Fuel system	Direct injection High pressure Common Rail Electronically controlled
Configuration	6 cylinders in line	Air intake	Turbocharged Air-to-seawater aftercooler
Operation type	4 strokes Diesel	Cooling	Closed cooling with heat exchanger
Bore & Stroke	106.4 x 127 mm [4.19 x 5 in]	Max mounting angle	0° Front down 12° Front up
Compression ratio	16.3 : 1	Alternator	24 Volt 50 Amp
Rated speed	2800 rpm	Rating	M5
Idling speed	600 rpm	Emission compliance	IMO Marpol Annex VI NRMM (97/68/EC) Tier 3 EPA marine Tier 3 RCD2 2013/53/EU
Peak torque	1230 Nm	Dry weight	735 kg [1620 lbs]
Peak torque speed	2200 rpm		

# N6.405 CR2

298 kW [405 hp] at 2800 rpm

## TECHNICAL DESCRIPTION

### ENGINE BLOCK

- Replaceable wet-type cylinder liners
- 4 Valves per cylinder
- Watercooled exhaust manifold

### FUEL SYSTEM

- Primary & secondary fuel filter
- Fuel heater
- Common Rail fuel injection system

### LUBRICATION SYSTEM

- Replaceable full-flow oil filter
- Oil dipstick
- Oil cooler

### COOLING SYSTEM

- Closed cooling with heat exchanger
- Gear driven self-priming raw water pump
- Coolant circulating pump
- Water cooled exhaust elbow

### ELECTRICAL SYSTEM & INSTRUMENTATION

- 24V / 50A alternator
- 24V starter motor
- Complete instrumentation including key switch and alarms
- Extension cable harness with plug-and-play

### AIR INTAKE

- Turbocharged
- Air-to-seawater aftercooler

### OTHER FEATURES

- Flywheel SAE 3
- Flexible engine mounting
- Damper pulley

### OPTIONAL SYSTEMS & ACCESSORIES

- Keel cooling adaptation
- Dry exhaust elbow
- Complete marine propulsion systems
- Marine transmission adaptation kits
- Throttle and shift controls
- Additional instrumentation, Flying bridge extension harness
- Rigid engine mounting
- Power take off

### RATINGS

- Up to 1000 annual operating hours
- Load factor up to 35%
- Full power for no ore than 30 minutes out of 8 hours of operation. The remaining operation time must be at or below cruising speed

### TRANSMISSIONS

- Contact your Nanni representative for more details and availability about transmissions types and models range.

## PERFORMANCE CURVES

### POWER AT CRANKSHAFT

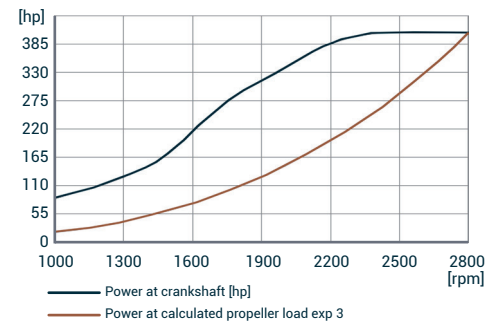

### TORQUE AT CRANKSHAFT

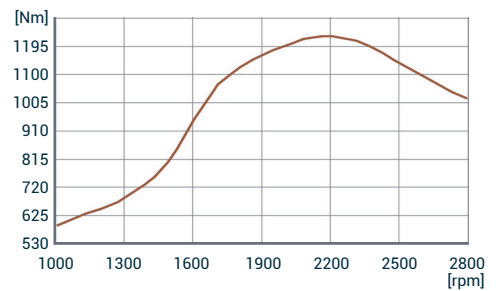

### FUEL CONSUMPTION

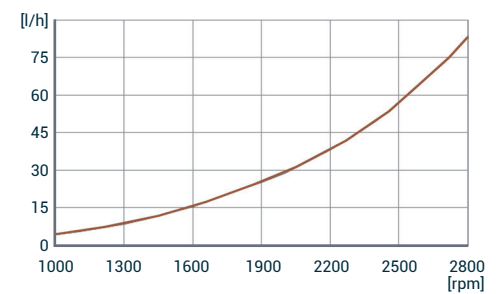

## DIMENSIONS

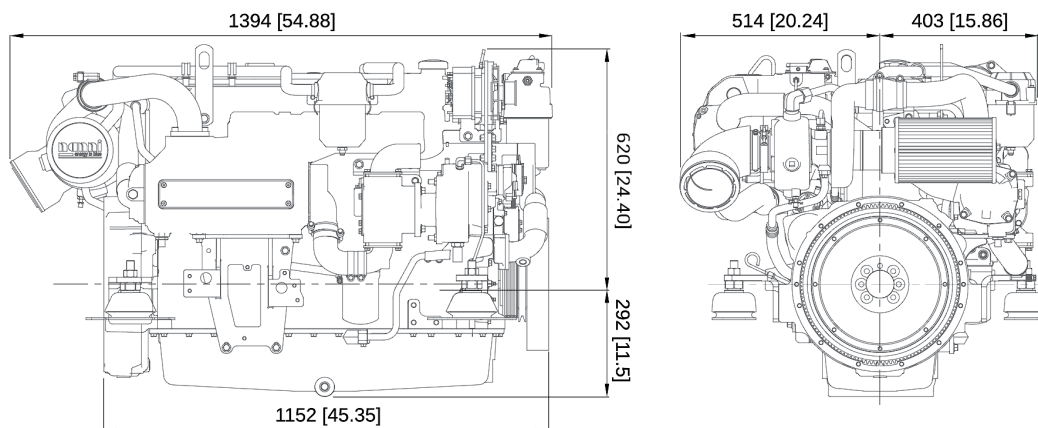

### NANNI INDUSTRIES S.A.S.

11, Avenue Abbé Mariotte  
33260 La Teste - France  
Tel +33 (0)5 56 22 30 60  
[www.nannienergy.com](http://www.nannienergy.com)

### NANNI SRL

Via degli Olmetti, 44/A  
00060 Formello - Roma - Italia  
Tel +39 06 30 88 42 51  
[www.nannienergy.com](http://www.nannienergy.com)

Technical data according to ISO 8665. This document is not contractual. Nanni reserves the right to modify any of the characteristics stated in this document without notice, in a constant effort to improve the quality of its products. Images and illustrations may show non standard equipments. All combination of equipment & accessory are not available.

DGBXXC01037B