

# N13.430 CR2

## SPECIFICATIONS

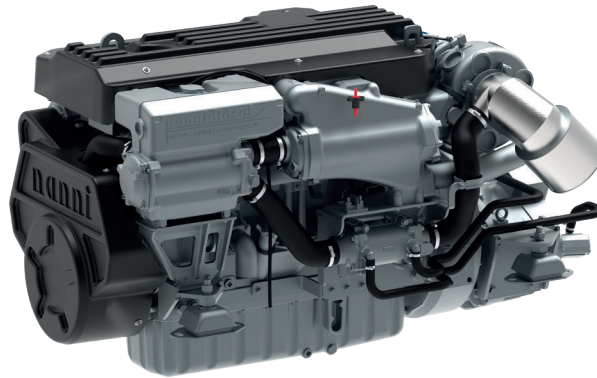

Power at crankshaft	317 kW [431 hp]	Engine base	John Deere
Displacement	13.6 l [830 in <sup>3</sup> ]	Fuel system	Electronically controlled unit injectors
Configuration	6 cylinders in line	Air intake	Turbocharged Air-to-seawater aftercooler
Operation type	4 strokes Diesel	Cooling	Closed cooling with heat exchanger
Bore & Stroke	132 x 165 mm [5.2 x 6.5 in]	Max mounting angle	0° Front down 12° Front up
Compression ratio	16 : 1	Alternator	24 Volt 100 Amp
Rated speed	1800 rpm	Rating	M1
Idling speed	600 rpm	Emission compliance	IMO Marpol Annex VI NRMM (97/68/EC) Tier 3 EPA marine Tier 3 RCD2 2013/53/EU
Peak torque	2328 Nm	Dry weight	1380 kg [3042 lbs]
Peak torque speed	1300 rpm		

# N13.430 CR2

317 kW [431 hp] at 1800 rpm

## TECHNICAL DESCRIPTION

### ENGINE BLOCK

- Replaceable wet-type cylinder liners
- 4 Valves per cylinder
- Directed top-liner cooling
- Watercooled exhaust manifold

### FUEL SYSTEM

- Electronically controlled unit injectors
- Primary & secondary fuel filter

### LUBRICATION SYSTEM

- Replaceable full-flow oil filter
- Oil dipstick
- Oil cooler

### COOLING SYSTEM

- Closed cooling with heat exchanger
- Gear driven self-priming raw water pump
- Coolant circulating pump
- Water cooled exhaust elbow

### ELECTRICAL SYSTEM & INSTRUMENTATION

- 24V / 100A alternator
- 24V starter motor
- Complete instrumentation including key switch and alarms
- Extension cable harness with plug-and-play

### AIR INTAKE

- Water cooled turbocharger
- Air-to-seawater aftercooler

### OTHER FEATURES

- Flywheel SAE 1
- Flexible engine mounting
- Damper

### OPTIONAL SYSTEMS & ACCESSORIES

- Keel cooling adaptation
- Dry exhaust elbow
- Complete marine propulsion systems
- Marine transmission adaptation kits
- Throttle and shift controls
- Additional instrumentation, Flying bridge extension harness
- Rigid engine mounting
- Power take off
- Type approval

### RATINGS

- 24 daily operating hours
- Load factor up to 65%
- Uninterrupted full power

### TRANSMISSIONS

- Contact your Nanni representative for more details and availability about transmissions types and models range.

## PERFORMANCE CURVES

### POWER AT CRANKSHAFT

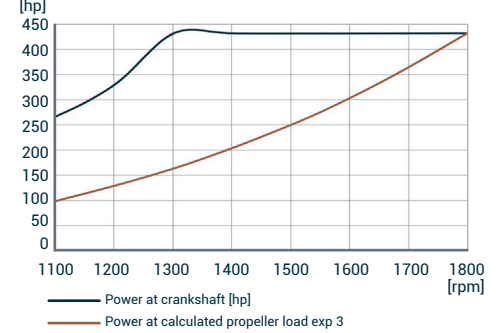

### TORQUE AT CRANKSHAFT

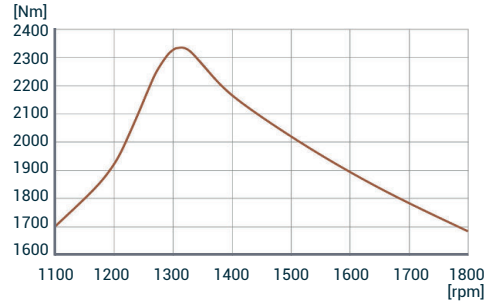

### FUEL CONSUMPTION

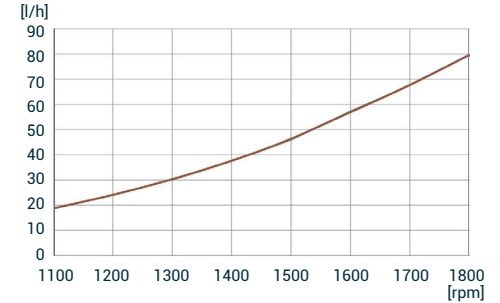

## DIMENSIONS

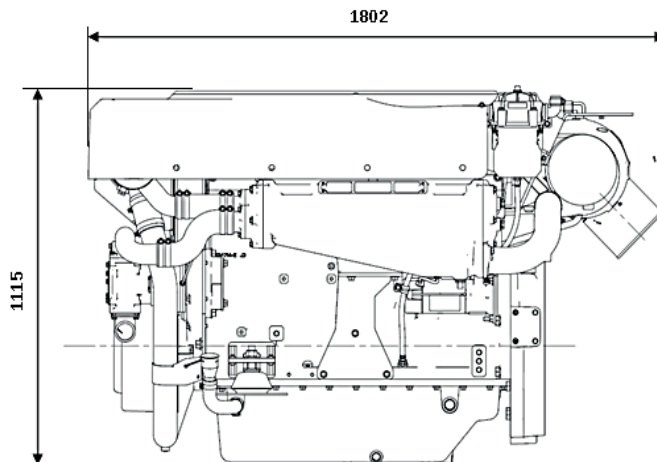
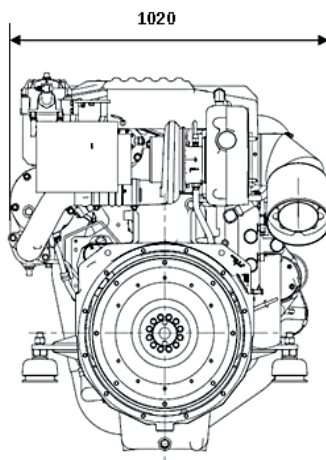

### NANNI INDUSTRIES S.A.S.

11, Avenue Abbé Mariotte  
33260 La Teste - France  
Tel +33 (0)5 56 22 30 60  
[www.nannienergy.com](http://www.nannienergy.com)

### NANNI SRL

Via degli Olmetti, 44/A  
00060 Formello - Roma - Italia  
Tel +39 06 30 88 42 51  
[www.nannienergy.com](http://www.nannienergy.com)

Technical data according to ISO 8665. This document is not contractual. Nanni reserves the right to modify any of the characteristics stated in this document without notice, in a constant effort to improve the quality of its products. Images and illustrations may show non standard equipments. All combination of equipment & accessory are not available.

DGBXXC01043B