

*New certification
RCD II*

Ghisellini Srl

Certificate by



Il motore LP 2.7 CR[®] è stato sviluppato su base motore VM

LP 2.7 CR – 198kW (270 CV) Marine Engine

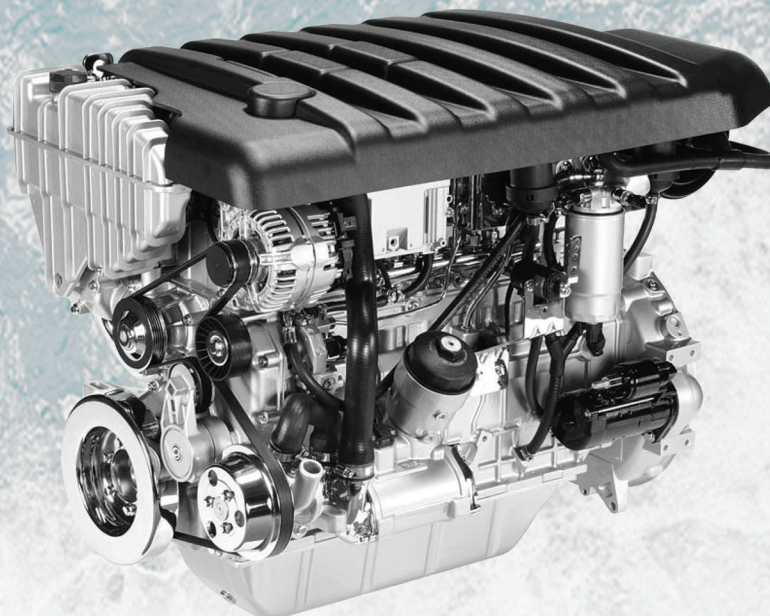

Dati tecnici motore

Motore tipo	LP 2.7 CR
Numeri di cilindri	6 in linea
Cilindrata	4.164 l
Alesaggio x Corsa	94 x 100 mm (3.7 x 3.94 in)
Raffreddamento	Acqua
Combustione	Iniezione Diretta Common Rail
Rapporto di compressione	17.5:1
Aspirazione	Sovralimentato ed interrefrigerato

Dimensioni e peso

Lunghezza	929 mm (36.6 in.)
Larghezza	758 mm (29.8 in.)
Altezza	788 mm (31 in.)
Peso (a secco in allestimento base)	460 kg (1014 lbs)

Potenza erogabile

Potenza netta massima	198 kW (270 CV) @3800 rpm
Coppia massima	670 Nm (68,3 kgm) @2400 rpm

Basic engine Data

Engine model	LP 2.7 CR
Number of cylinders	6 in line
Displacement	4.164 l
Bore and Stock	94 x 100 mm (3.7 x 3.94 in)
Cooling	Water
Combustion	Direct Injection Common Rail
Compression Ratio	17.5:1
Induction	Turbocharged and intercooled

Dimensions and weight

Length	929 mm (36.6 in.)
Width	758 mm (29.8 in.)
Height	788 mm (31 in.)
Weight (dry with all standard equipment)	460 kg (1014 lbs)

Rated power output

Maximum power	198 kW (270 CV) @3800 rpm
Maximum torque	670 Nm (68,3 kgm) @2400 rpm

Potenza / Power

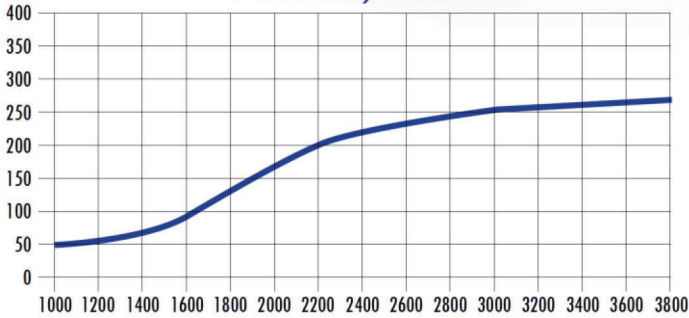

Coppia / Torque

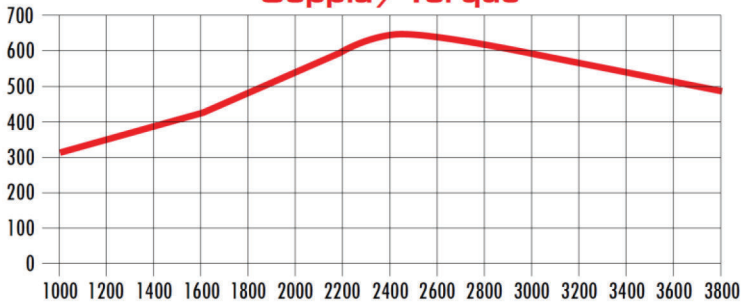

Consumo Specifico / Specific Consumption

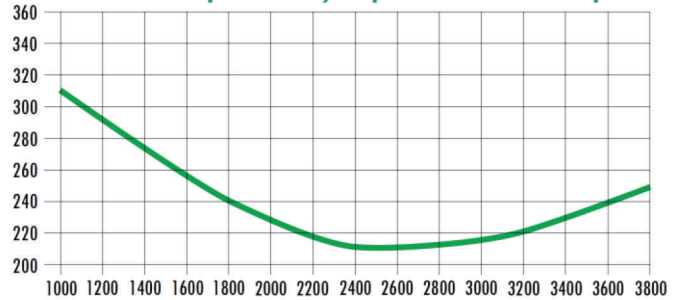

Allestimento base

- Campana coprivolano SAE
- Motorino di avviamento 12V
- Alternatore 12V-110A
- Filtri olio e combustibile
- Filtro aria
- Raffreddamento motore ad acqua dolce con scambiatore di calore ad acqua di mare
- Raffreddamento olio motore con scambiatore di calore raffreddato ad acqua di mare
- Raffreddamento del collettore di scarico e della turbina ad acqua dolce
- Pompa circolazione acqua di mare in bronzo con girante in gomma speciale
- Pompa centrifuga per la circolazione dell'acqua dolce
- Pompa estrazione olio dalla coppa
- Vaso espansione acqua incluso
- Miscelatore gas di scarico/acqua mare in acciaio inox
- Supporti elastici
- Cruscotto con strumenti elettrici ed allarmi
- Prolunga per cruscotto di mt. 8
- Verniciatura colore bianco

Standard equipment

- SAE flywheel housing
- Starter motor 12V
- Alternator 12V-110°
- Oil and fuel filters
- Air filter
- Freshwater engine cooling system with seawater heat exchanger
- Engine lubricating oil cooled by heat exchanger seawater cooled
- Freshwater cooled exhaust manifold and freshwater turbocharger
- Bronze seawater circulating pump with impeller in special rubber
- Centrifugal pump for freshwater circulation
- Drain oil pump
- Expansion tank integrated
- Stainless steel exhaust gas/seawater mixer
- Flexible mounts
- Electrical instrument panel with alarms
- 8 m. panel cable extension
- White paint finish

Applicazioni a richiesta

- Invertitore idraulico
- Cruscotto per fly bridge

Optional equipment

- Hydraulic reverse/reduction gear
- Fly bridge dashboard

Dimensioni d'ingombro / Dimensional drawing

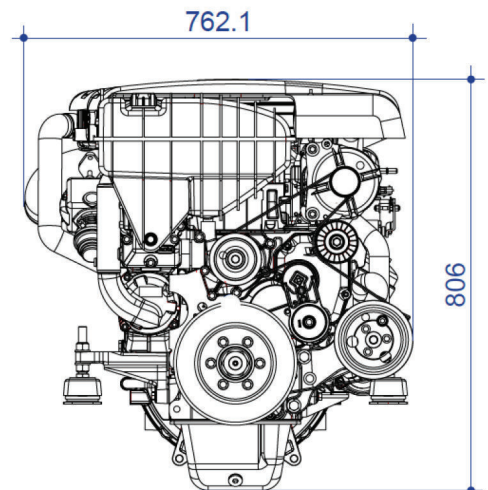
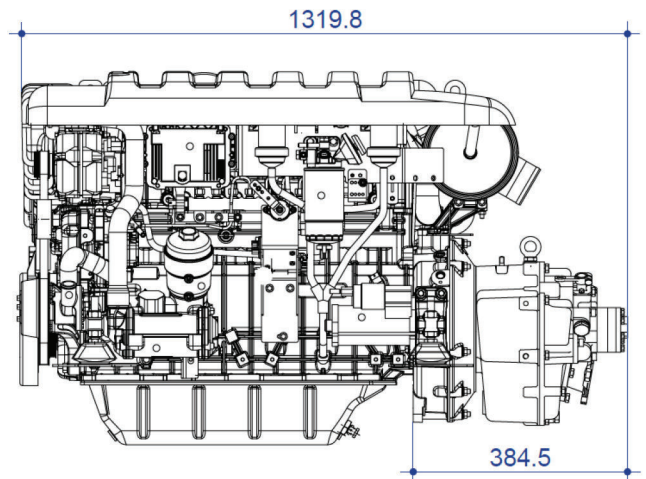

Ghisellini srl

Via del Lavoro, 9 44041 - Casumaro (FE)
 Capitale sociale: € 10.000,00 i.v.
 Cod. Fiscale / P. IVA: 02066970381
 Iscrizione R.E.A. FE n° 223056
 E-Mail: info@ghisellinisrl.it
 Tel 051/6849978 - Fax 051/6846852
 Web: www.ghisellinisrl.it